

POWERAMP

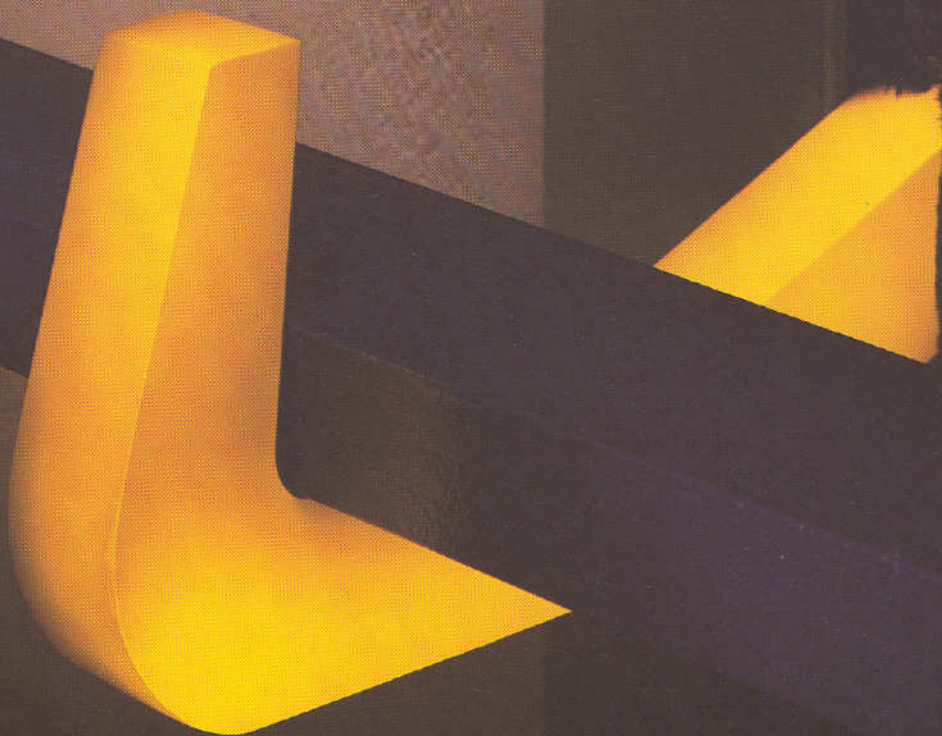

POWERHOOK™

Poweramp PowerHook™ II Truck Restraints.

Dock safety depends on many factors: alert, safety-conscious personnel; equipment that's in good operating condition; and, most important, a reliable truck restraining system. A restraining system such as the hydraulic PowerHook II™ from Poweramp.

The PowerHook II truck restraint is the only device available that seeks, finds and maintains a tight continuous hold on the ICC bar throughout loading and unloading operations. It's programmed to operate both vertically and longitudinally to eliminate any gap between the hook and ICC bar, effectively eliminating "trailer creep." For added safety, when PowerHook II is equipped with the leveler interlock option, it will not permit leveler operation until the hook is engaged.

PowerHook II is firmly anchored in the loading dock pit for maximum holding power. The hook remains protected behind the pit wall until activated. The PowerHook II restraint is designed to withstand a pulling force of 35,000 lbs., giving you an extra margin of safety and protection. PowerHook II operates within a 20" vertical range . . . from 10" to 30" is standard. Its horizontal range is 1" to 15" from the building wall.

PowerHook II is the only unit available that stores in the pit, completely concealed and out of the way. This is a great advantage when clearing the driveway approach of snow or debris.



PowerHook II control

PowerHook II is controlled by the most advanced electronics in the industry. Not only does it perform all PowerHook II functions, but it can be programmed to combine with existing security and energy conservation systems for increased convenience and efficiency. New operational procedures and additional equipment can be easily added as they are needed.



DockAlert™ three-light communication

It's essential to dock safety that drivers and dock personnel communicate clearly with each other. The three-light DockAlert system, standard with PowerHook II restraints, coordinates dock activities to help prevent accidents from happening. Pressing the PowerHook II control button automatically activates the PowerHook II restraint, your dock leveler, and the DockAlert system. As a truck backs into your dock, a steady green light tells the driver that it's safe to proceed. Inside, a flashing red light warns dock personnel that a trailer is not secured. Once PowerHook II engages and secures the ICC bar, a green light inside signals all clear. Outside, the light signals flashing red, warning the driver not to pull away.

PowerHook KS5

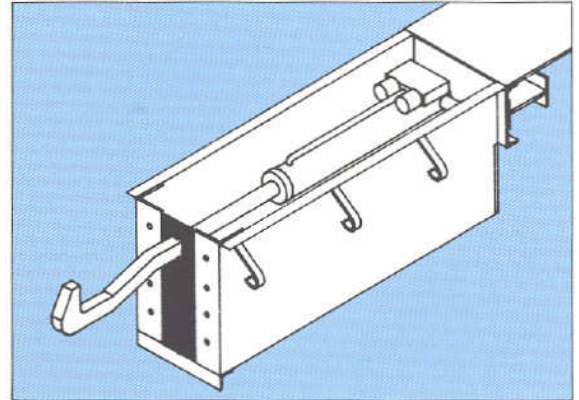
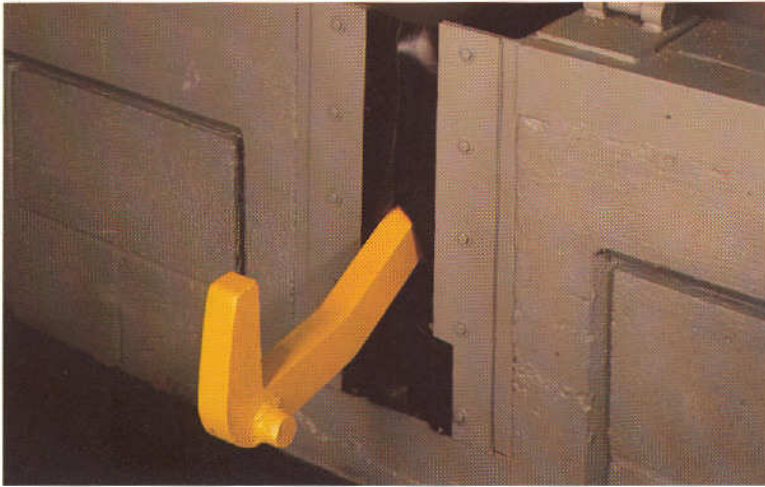

The PowerHook™ II KS5 pan-type truck restraint is an economical retrofit for hydraulic dock levelers. All that's required is a minimum 44" dock height.

PowerHook KS6

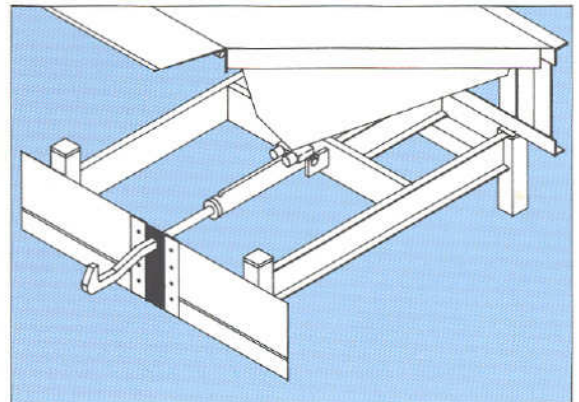

The PowerHook II KS6 is mounted on a stand that slides into any new or existing full-depth pit. It's easy to install . . . just weld it into position and run power to it.

PowerHook KS7

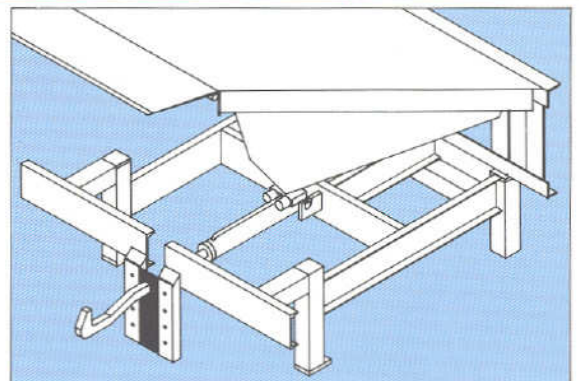

The PowerHook II KS7 is a stand-mounted restraint that's ideal for retrofit or new construction. Front legs of stand are recessed so that concrete or block wall can be constructed to give your dock a clean, finished look.



POWERAMP[®]

Systems, Inc.
W.194 N.11481 McCormick Dr.
P.O. Box 309
Germantown, Wisconsin 53022
1 (800) 643-5424
(262) 255-1510 FAX: (262) 255-4199
www.sales@poweramp.com

Manufacturing facilities in the Netherlands with sales offices throughout Europe.