

## “HM” Series Mechanical

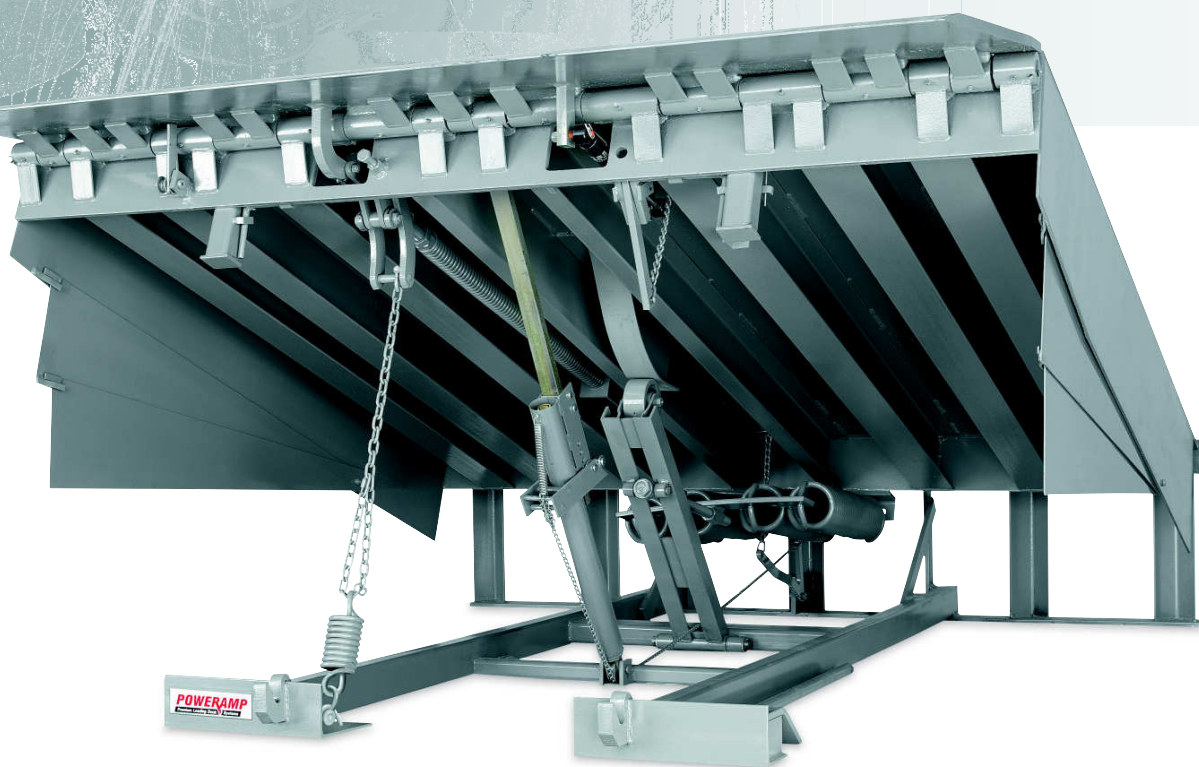

HM Series 7'x 8' 50,000 CIR, Full Range Toe Guard and CleanSweep Frame™ shown.

### HM Series Standard Features Include...

- Structural Steel Support Members
- Multi-Position Structural Steel Safety Legs
- Below Dock End Loading Control
- Extended Range Float/Hold-Down Mechanism
- Yieldable Lip Plate
- Camcontrol™ Counter Balance Assembly
- Lip Drive™ Positive Lip Extension
- CleanSweep Frame™
- Lockout/Tagout Maintenance Strut
- Night Locks/Cross Traffic Support
- 3-Wheel Forktruck Protection
- Lip Support Service Strut
- Working Range Toe Guards
- Grease Fittings
- B410-14 Laminated Bumpers

# Pit Style Levelers Mechanical

Value,  
Power and  
Performance  
In One  
Design!

## Structurally Superior By Design!

When size does matter, choose Poweramp HM Series Heavy-Duty Mechanical Leveler. With our 29" of direct rear hinge support and a high strength deck constructed of structural "C" and/or a combination of structural "I" and "C" channels, you'll be hard pressed to find another product on the market who's structure compares.



Our Cam Control™ Counter Balance Assembly permits smooth ramp extension and easy "walk-down" of the leveler through the use of a precision lifting roller and metered cam assembly.



The HM Leveler comes standard with a heavy-duty, extended range, float barrel hold down mechanism. An automatic release feature protects the device under extreme float conditions common when "air-ride" suspension trailers are serviced. Fingertip release of the hold-down makes activation or storing this ramp a snap.



The Lip Drive™ positive lip extension reliably extends the leveler lip and restricts its descent until walk-down is performed. A gas filled shock meters the descent of the lip and is reliable in all climate conditions.



Periodic maintenance, inspection and clean up is made easy with the HM Series Leveler. Our CleanSweep Frame™ allows unobstructed access to the pit area and is standard on all HM Levelers. The maintenance strut is permanently mounted and lockout/tagout compliant. A separate lip support permits independent support and servicing of the deck and lip.

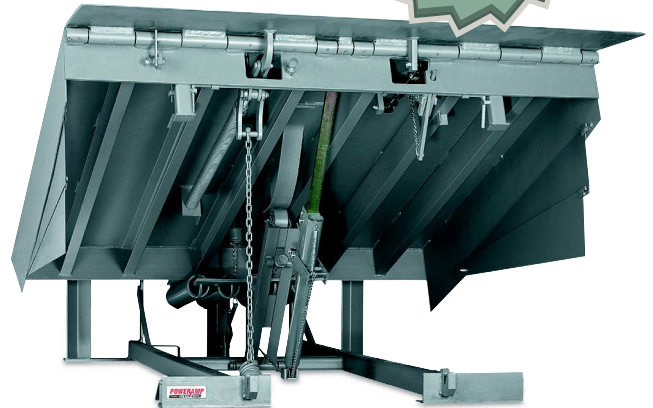

HM Series 6'x 8' 30,000 CIR with CleanSweep Frame™ and Full Range Toe Guards shown.

### HM Series Common Options...

- Extended Lip Sizes (18" and 20")
- Weatherseal (Brush Or Rubber)
- Full Range Toe Guards
- Foam Insulated Deck
- Vertical Dock Bumpers
- Dock Alert Light Communication Package
- Integrated Vehicle Restraint
- Dock Light

**The HM Series Mechanical Leveler is available in a wide range of sizes and capacities and can be modified for special applications.**

Distributed By:

**Pace**  
Equipment Company  
Wilsonville, OR  
(503) 682-4447  
www.paceequipmentco.com

A Division of Systems, Inc.  
**POWERAMP**  
Premium Loading Dock Systems