

MOBI-DOCK CMD SCISSORS LIFT

The MOBI-DOCK is a configurable, low profile, light duty portable dock lift. It is designed especially for situations where no dock exists.

The MOBI-DOCK provides up to 4,000 lbs. capacity and up to 56" raised height.

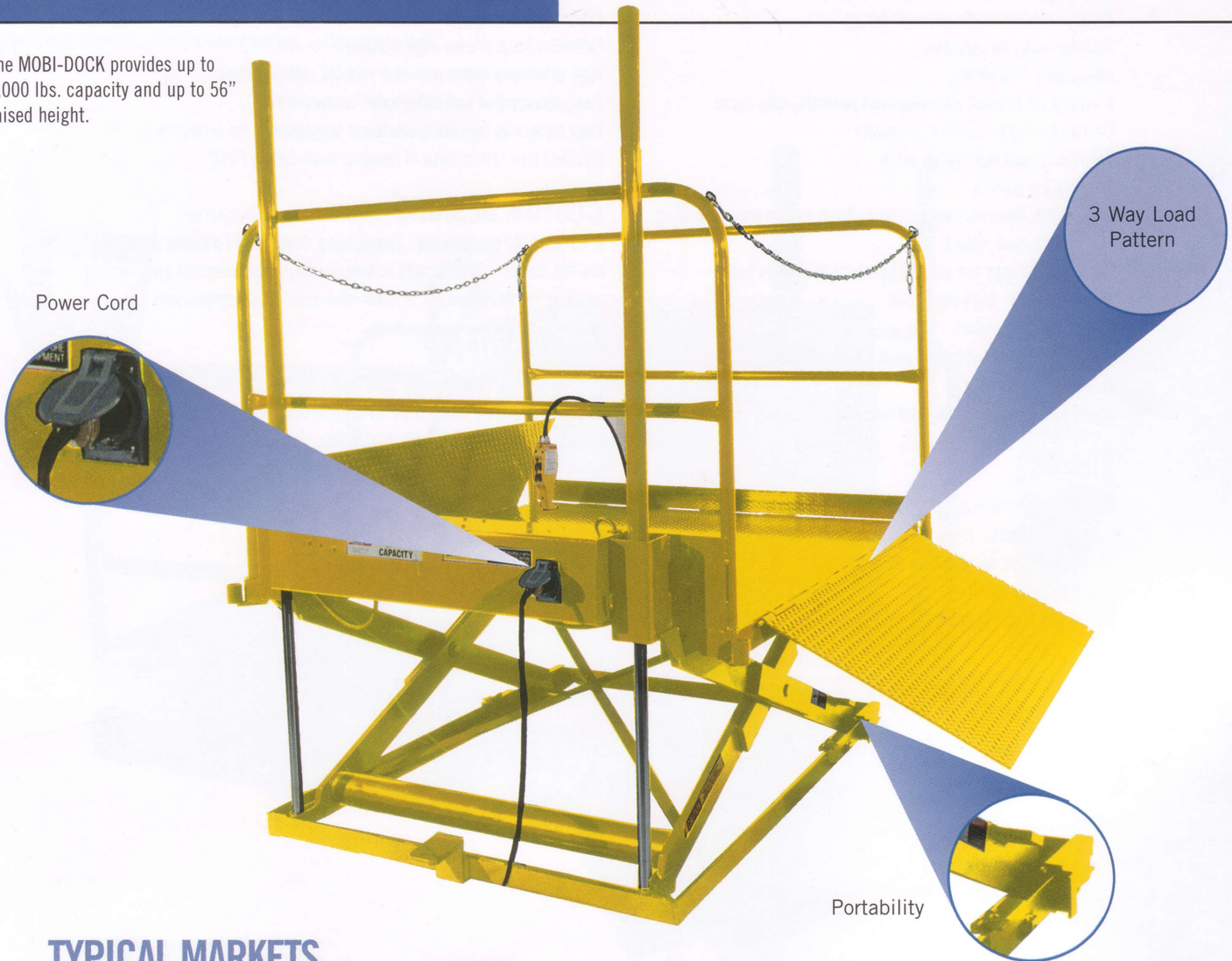

TYPICAL MARKETS

Automotive | Postal | Retail Outlet | Food & Drug



KEY FEATURES

- Lubricated-for-life Composite bearings on all pivot points
- Solid steel legs
- Platform surface constructed of 4-way tread plate
- Turned, ground, polished and hard-chromed axle pins
- Double-wire braided hydraulic hoses
- Velocity fuses on cylinders
- Internally mounted 2 hp motor
- Prewired UL labeled and approved control components
- Factory tested to 110% of capacity
- Chrome-plated cylinder rods
- Flip down wheels for transporting unit
- 30" x 60" hinged approach ramp
- 18" x 60" hinged throwover bridge
- 1 Permanent and 1 Removable 48" high handrails
- Built and designed in accordance with ANSI MH29.1

OPTIONS

- Bumper for added housing protection
- PS. Options * - "Postal Package" which meets the requirements of published Federal Specifications

BENEFITS

- Maintenance free bearings, no greasing
- Zero platform deflection in lowered position
- Extended bearing life
- Extended hose life for added safety
- High efficiency motor provides faster raising times
- Easy servicing of hydraulic valve components
- Easy access to hydraulic/electrical components for servicing
- Free fall arrested in case of severed hose-Safety First!
- Easy to relocate to different dock or facility

VERSATILITY

- Approach ramp, bridge and handrails are removable and can be positioned on any of three open sides.

POWER SUPPLY

- The standard 2 hp electric motor is 230VAC, 60 cycle, 1 phase.

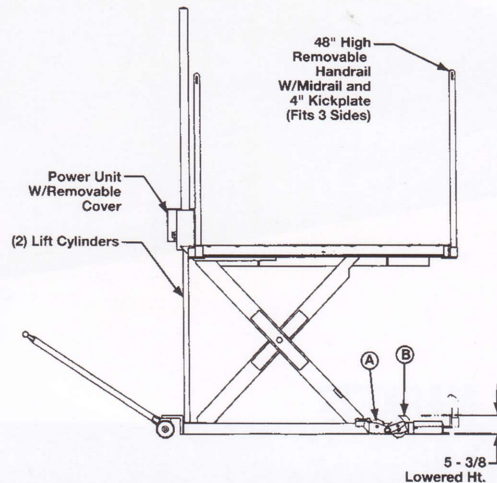
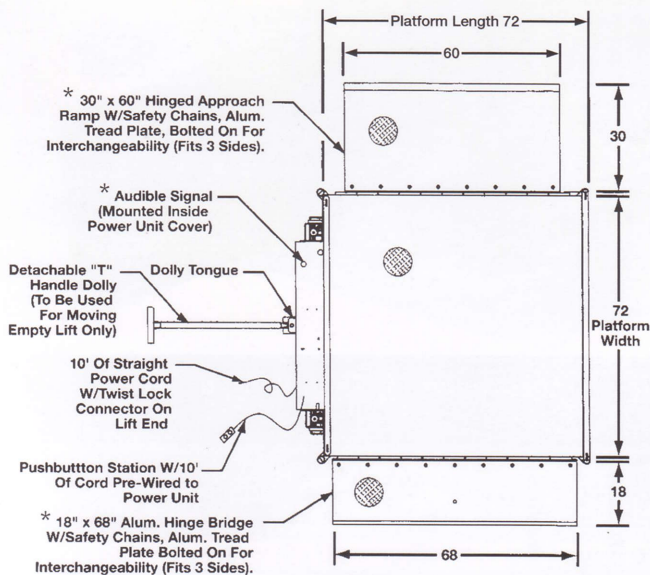
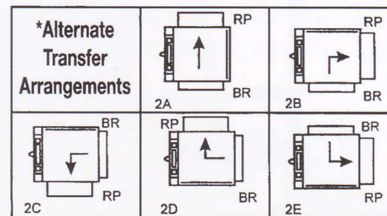

MOBI-DOCK CMD SCISSORS LIFT

SPECIFICATIONS: Capacities – 3,000 & 4,000 lbs. - Raised Height To 57"

Travel (inches)	Capacity (pounds)	Base Frame Size (inches)	Platform Sizes (inches)	Axle Load Capacity Over Bridge End (pounds)	Axle Load Capacity Opposite Bridge End (pounds)	Axle Load Capacity Over Sides (pounds)	Lowered Height (inches)	Raised Height (inches)	Nom. Std. Speed (FPM)	Std. Motor HP (230/60/3)	No. of Rams	Shipping Weight (pounds)	Model
50	3,000	60 x 75	72 x 72	1,500	1,500	1,500	5 3/8	56	8	2	2	2,400	CMD 30
50	4,000	60 x 75	72 x 72	2,000	2,000	2,000	5 3/8	56	8	2	2	2,500	CMD 40
50	4,000	60 x 75	72 x 72	2,000	2,000	2,000	5 3/8	56	8	2	2	2,600	CMD-PS*